

Nassabscheider HydroTower

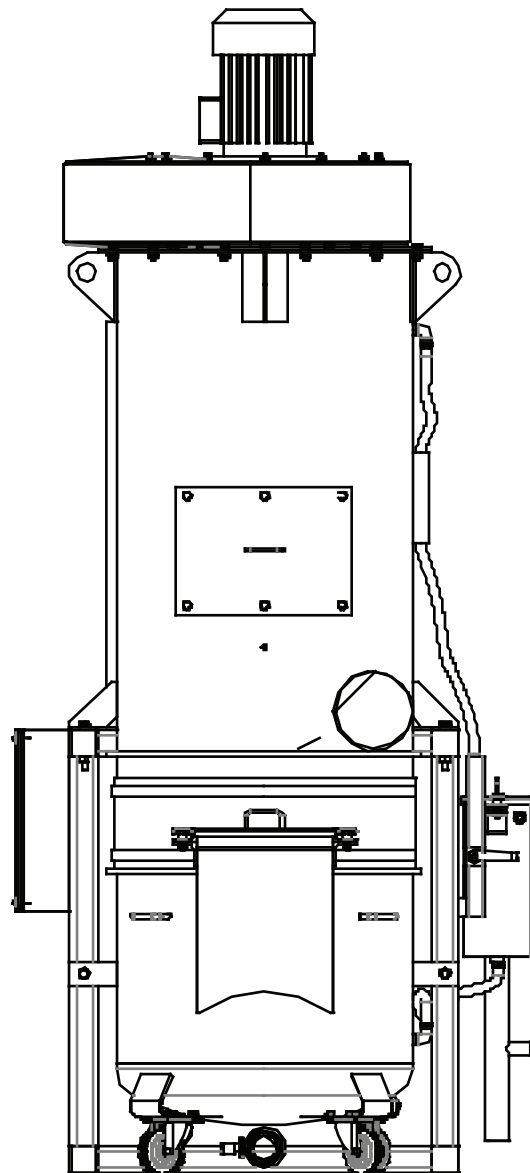

Chemill GmbH
Oststrasse 1
06526 Sangerhausen
Germany

0049 (0)151 677 914 66
www.chemill.net

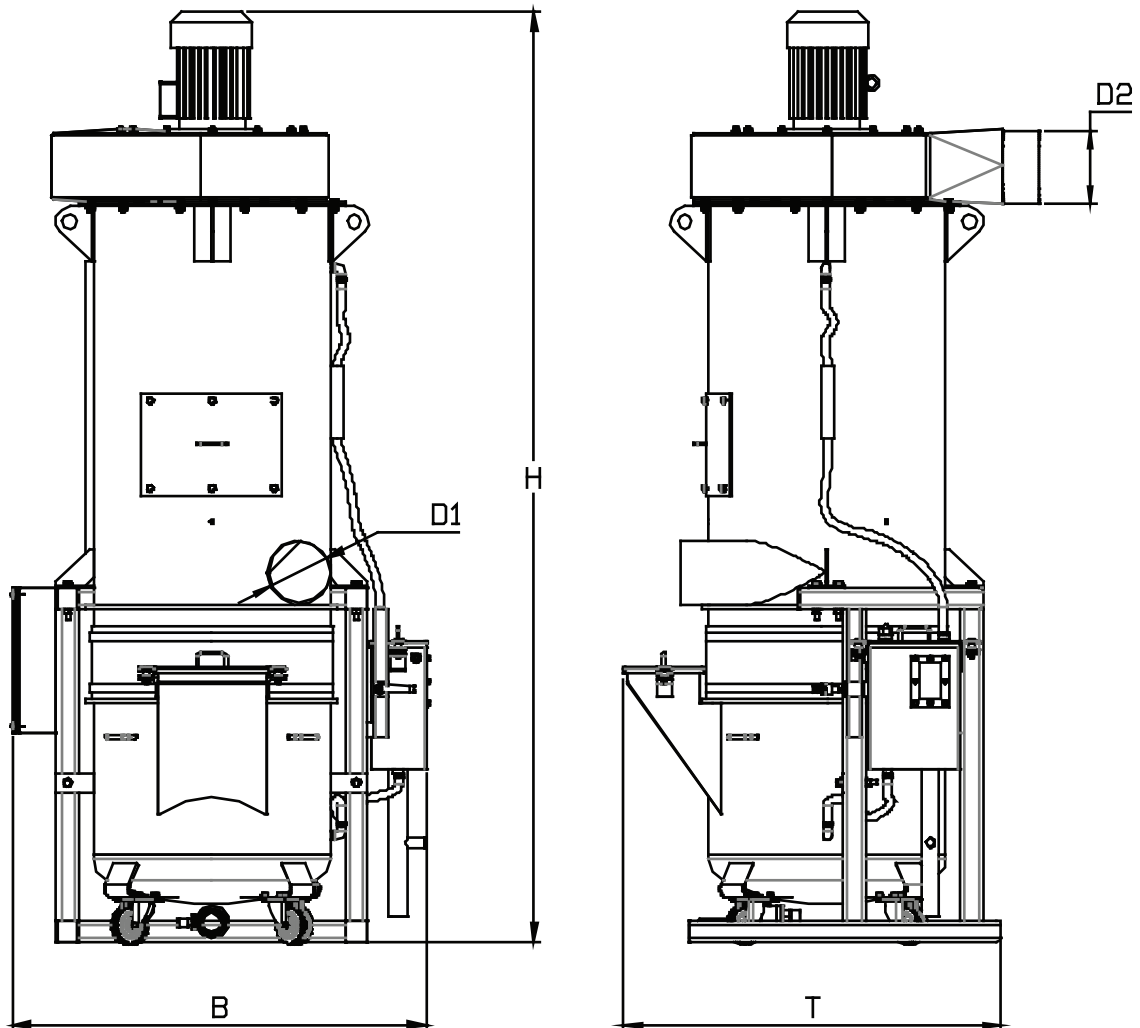

Modell		64	80	95	130
Max. Luftmenge	m ³ /h	2000	3000	4000	6000
Max. Unterdruck	Pa	3000	3400	3400	3200
Durchmesser Eingang	mm	175	200	250	315
Durchmesser Ausgang	mm	200	250	315	350
Motorleistung	kW	3	4	7,5	15
Wasserinhalt	l	165	320	420	580
Breite	mm	1150	1400	1500	2200
Tiefe	mm	1000	1250	1500	1800
Höhe	mm	2500	3150	3500	4200
Gewicht	kg	280	340	420	580

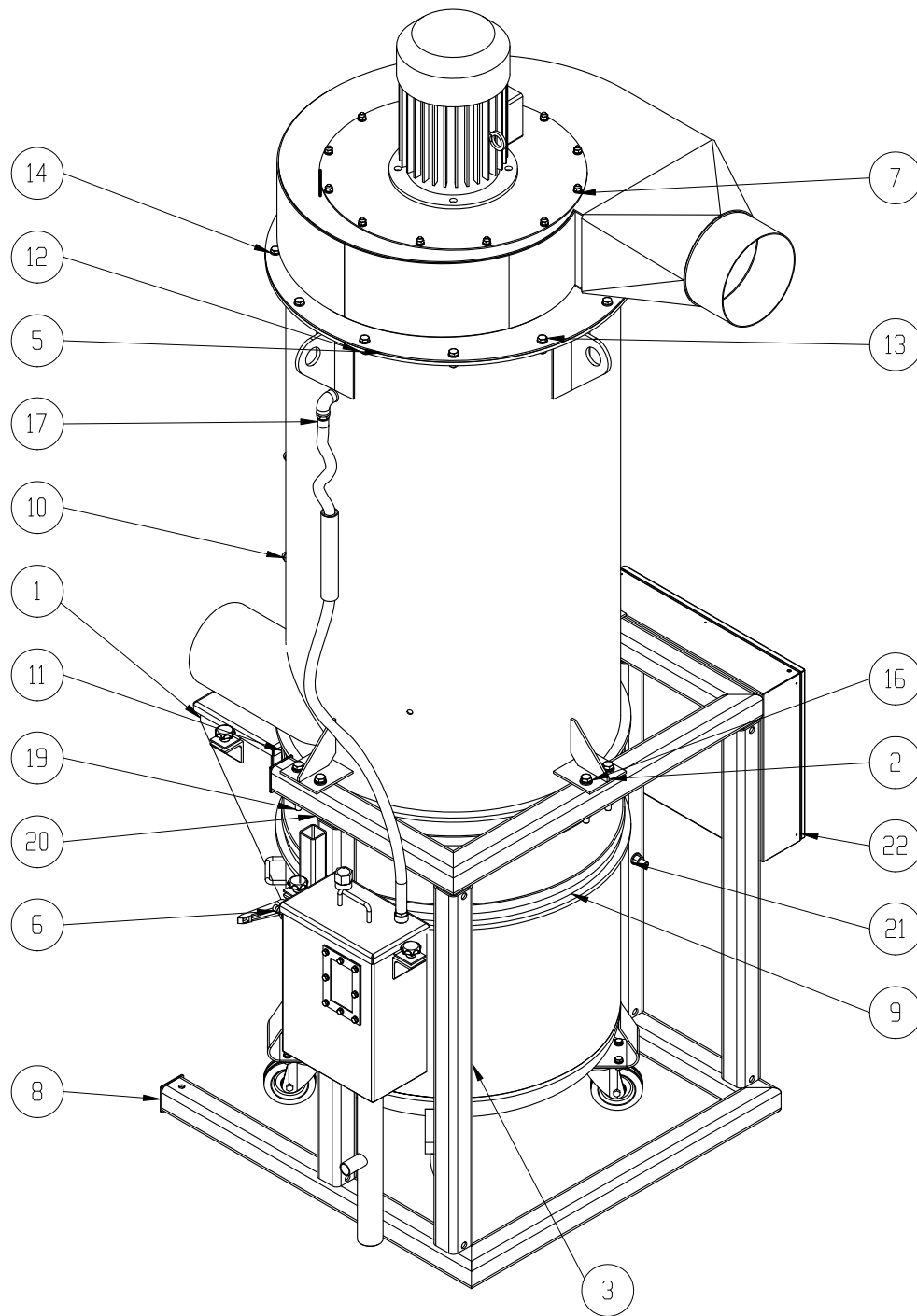

Nr.	Bezeichnung
1	Schlammkessel
2	Gehäuse
3	Ständer
4	Demister
5	Deckel
6	Regelung Wasserstand
7	Ventilator
8	
9	Gummi-Manchette $\phi 650$ L=200mm
10	
11	Rohrschelle $\phi 650$
12	
13	
14	
15	
16	
17	Schlauch
18	Schlauch
19	
20	
21	
22	1 Schaltschrank